

Cistern Mechanism

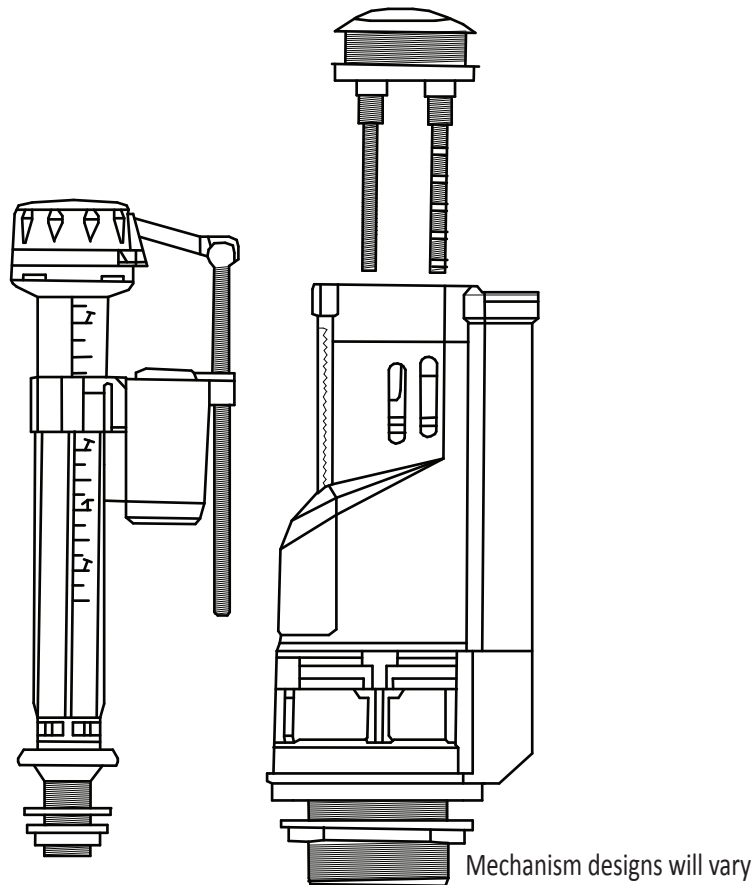

1 Person
Installation

Installation Manual

Please keep these instructions for future reference

Installing the Cistern Mechanism

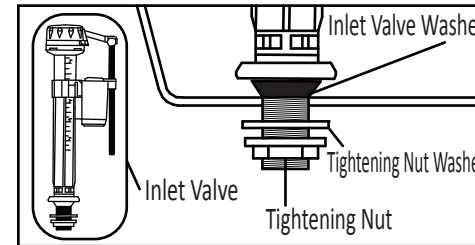

1. Install the Inlet Valve by removing the Tightening Nut and Tightening Washer and then place the threaded part of the valve through the inlet hole on the base of the cistern ensuring the Inlet Valve Washer is evenly position in the hole. Place the washer back over the screw thread and secure the Tightening Nut against the base of the cistern.

2. Release the Float Adjustment Rod from the Inner Float and adjust the Outer Float to the desired height. Reattach the Float Adjustment Rod onto the Inner Float ensuring the Float Adjustment Rod is sat at its most downward position when secured.

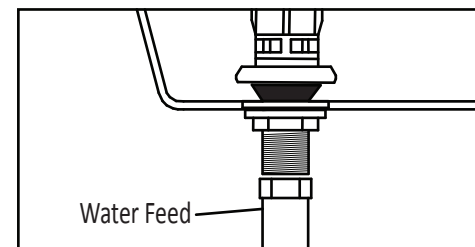
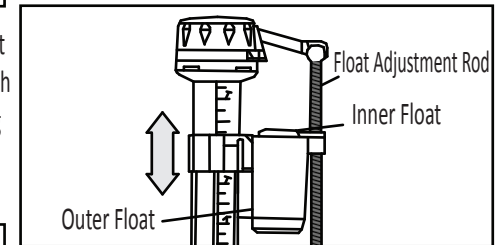

3. Securely attach the water feed pipe to the thread on the Inlet Valve ensuring the connection is water tight.

4. If using the Flush Mechanism on a One-Piece toilet, the Flush Mechanism will need to be dismantled by rotating the upper and lower sections of the Flush Mechanism in opposite directions. Once completed, the lower section can be placed through the central hole on the inside of the basin. Ensure the 'U' Bracket underneath is sitting flat on the underside of the cistern and tighten the screw. The upper section can then be re-attached to the lower section of the Flush Mechanism.

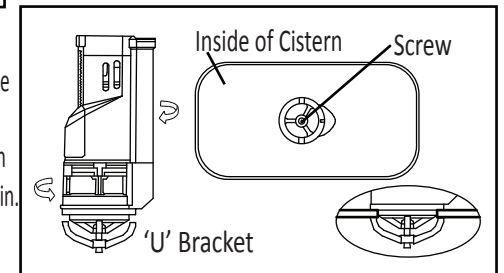

If using the Flush Mechanism on a Two-Piece toilet, it can simply be placed through the hole on the Cistern and secured using the Locking Nut.

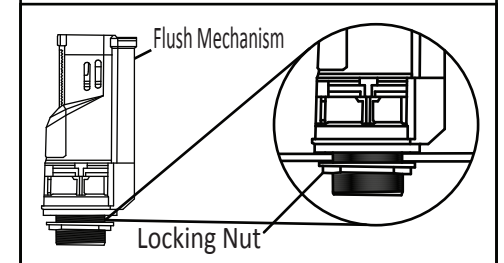

Setting up the Flush and Button

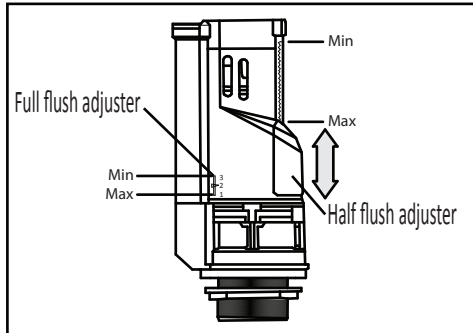

5. The Flush Mechanism can be adjusted on both the Full and Half Flush button to optimise the performance.

Note: The Cistern Mechanism has an internal overflow therefore removing the need have a separate overflow feeding out of the cistern. The internal overflow siphons overflowing water straight down through the centre of the flush mechanism.

6. The button can now be attached to the Cistern Lid by placing the button through the hole and securing using the Locking Nut. Before tightening, make sure the Rods align correctly with the push buttons on top of the Flush Mechanism.

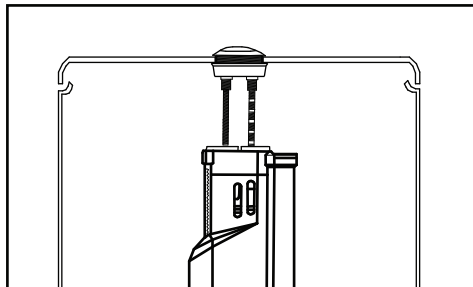
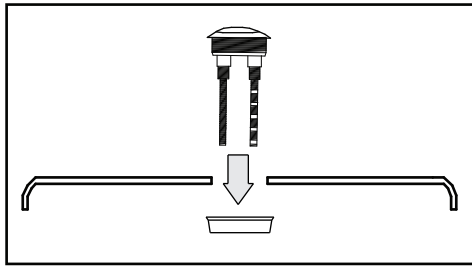

7. The length of the Rods can be adjusted amending how far the Rod is screwed into the Mechanism. They can also be cut down if they are too long but be very careful not to cut the Rods too short.

Problem Solving

No Partial Flush - Check that the water level is higher than the partial float. If not, adjust the inlet valve to increase the water level height or reduce the height of the float.

Little or No Flush - 1. Check that the button is in the correct position
2. Ensure the push button rod is not too short. It may need to be lengthened to engage the full flush.

Thank you!

Thank you for buying this product from bathrooms.com.

We hope you are fully satisfied with the product and service we provide.

If you need any further help or advice with your purchase, then please feel free to call our customer service team on the number below or alternatively you can email us at sales@bathrooms.com

www.bathrooms.com

Customer Service: 0845 833 4441

Technical Support: 01525 300 751

email: sales@bathrooms.com

bathrooms.com